

GOLDEN ENGINEERED "RUN ABOUT" 4 POST, 2 MOTOR BOAT LIFTS

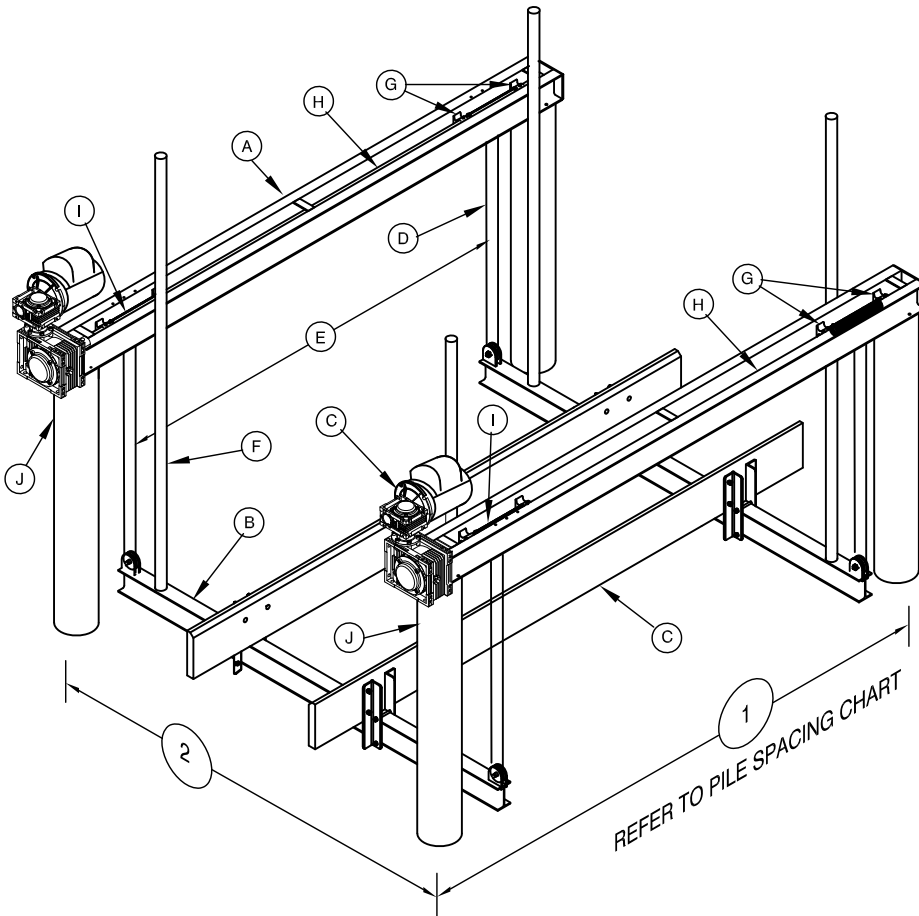

PILE SPACING CHART
The boat center of gravity
needs to be set in the center
of the top beam

Lift Capacity	"1" Dimension	"2" Dimension	Recommended Pile Diameters
4,500 #	8'-4"	10'-0"	(4) 8"φ (min)
6,000 #		12'-0"	
9,000 #	12'-0"	12'-6"	
12,000 #			

STAINLESS STEEL PILING
MOUNT BRACKET, 4 -
3/8" STAINLESS STEEL
LAG SCREWS USED TO
CONNECT THE BRACKETS
TO THE PILING AND 2 -
3/8" CARRIAGE BOLTS
USED TO CONNECT THE
BRACKETS TO THE LIFT
CHANNELS

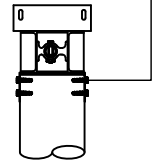

NOTE: THIS STRUCTURE WILL WITHSTAND WIND LOADS ASSOCIATED WITH AN ULTIMATE WIND SPEED OF 180 MPH, EXPOSURE "D" CALCULATED PER F.B.C. 8th EDITION 2023, ADM 2020 AND ASCE/SEI 7-22.

BOATS SHALL NOT BE STORED ON LIFT DURING HIGH WIND EVENTS

IN GENERAL, PILING PENETRATION TO BE 10' INTO THE SAND BOTTOM OR 5' INTO THE ROCK STRATA. SUB-SURFACE CONDITIONS CAN VARY GREATLY, THE CONTRACTOR SHALL VERIFY ALL PILE CAPACITIES. ALL PILING TO BE 2.5 C.C.A. TREATED

	(A)	(B)	(C)	(D)	(E)	(F)	(G)	(H)	(I)	(J)		
LIFT CAPACITY	TOP BEAM CHANNEL 2 EACH	CRADLE I-BEAM 2 EACH	BUNK BOARDS (PT)	STAINLESS STEEL CABLE	CABLE SPREAD	GUIDE POST HGTH	BRGS	DRIVE SHAFT	WINDER	MOTOR HP VOLTAGE	INCHES OF LIFT PER MIN	RECOM PILING SIZES
4,500 #	4" H x 0.15 2" W x 0.23 108" O.A.L.	6" H x 0.19 4" W x 0.29 120" O.A.L.	2x8 x 12'-0" FULLY CARPETED	(4) 1/4"φ x 15'-0" 1 PART	78"	80"	(10) 1.5" EXTRUDED 6061-T ALUM.	1-1/2" SCHEDULE 80 GALVANIZED STEEL PIPE	2" SCHEDULE 80 6061-T6 ALUM. PIPE	3/4 HP 1725 RPM 110/220V	27"	(4) 8"φ (min)
6,000 #		6" H x 0.19 4" W x 0.29 144" O.A.L.		(4) 5/16"φ x 15'-0" 1 PART								
9,000 #	5" H x 0.15 2.25" W x 0.26 153" O.A.L.	6" H x 0.21 4" W x 0.35 144" O.A.L.		(4) 5/16"φ x 30'-0" 2 PART	110"							
12,000 #	6" H x 0.17 2.5" W x 0.29 153" O.A.L.	8" H x 0.23 5" W x 0.35 150" O.A.L.										