

When It's Done Right...It's Golden!



# **2K THRU 14K**

# **3V 3T GATORVATOR**

# **INSTALLATION**

# **MANUAL**



17611 East Street, North Fort Myers, FL 33917

TF: 888-909-5438 PH: 239-337-4141 FAX: 239-337-4482 [www.goldenboatlifts.com](http://www.goldenboatlifts.com)

# GOLDEN BOAT LIFT THREE PILING INSTALLATION

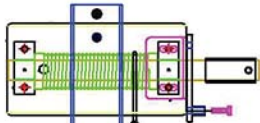

Position the drive spool 4 to 6 feet above the dock on the inboard side of the piling.

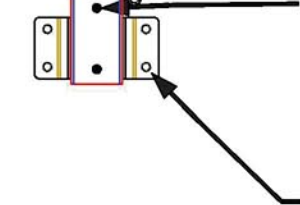

Mark the four holes and drill 3/4" diameter thru the piling. Using the threaded rod and backer plates, mount the Drive Spool on the piling.

Complete the installation by installing lag screws on the side tabs. Repeat for the second spool if you have a two motor lift.

Upper Tie-Off Bracket

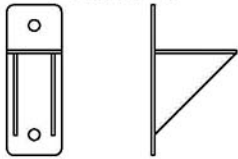

Single Motor

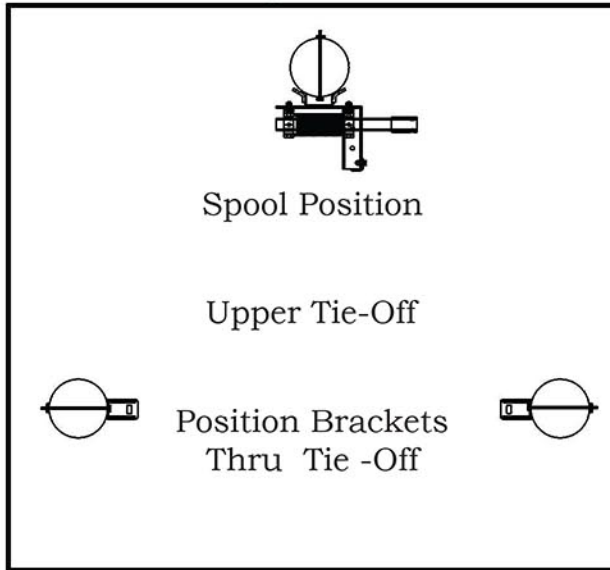

Two Motor

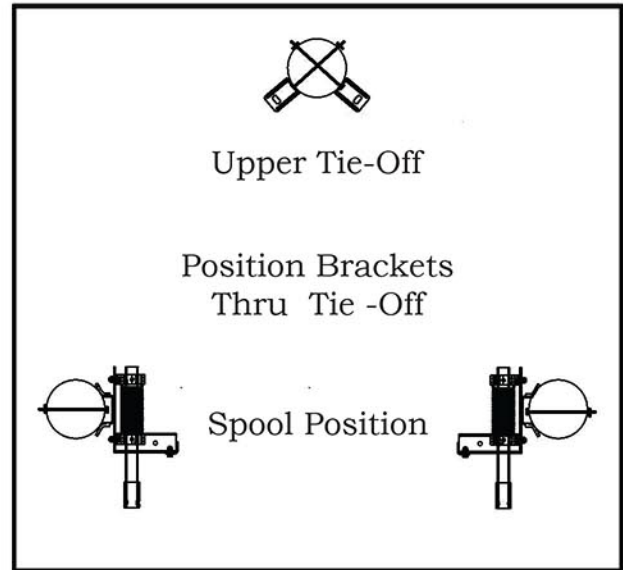

Position the upper Tie-Off brackets as shown, 1 to 3 feet above the highest point the cradle beam can go. Thru bolt with 3/4" bolts and backer plates provided.



17611 East Street, North Fort Myers, FL 33917

TF: 888-909-5438 PH: 239-337-4141 FAX: 239-337-4482 [www.goldenboatlifts.com](http://www.goldenboatlifts.com)

# GOLDEN BOAT LIFT THREE PILING INSTALLATION

Lower Cable  
Tie-Off

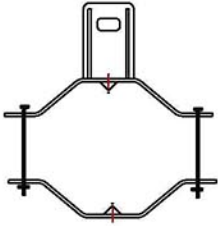

Place the lower tie-off bracket directly below the drive spool and 2 feet above the lowest cradle-beam position.

**CAUTION:** Upper arm pulley must be above BKT.

Clamp bracket and backer plate with the bolts provided.

Tighten bolts driving wedge points into the piling.

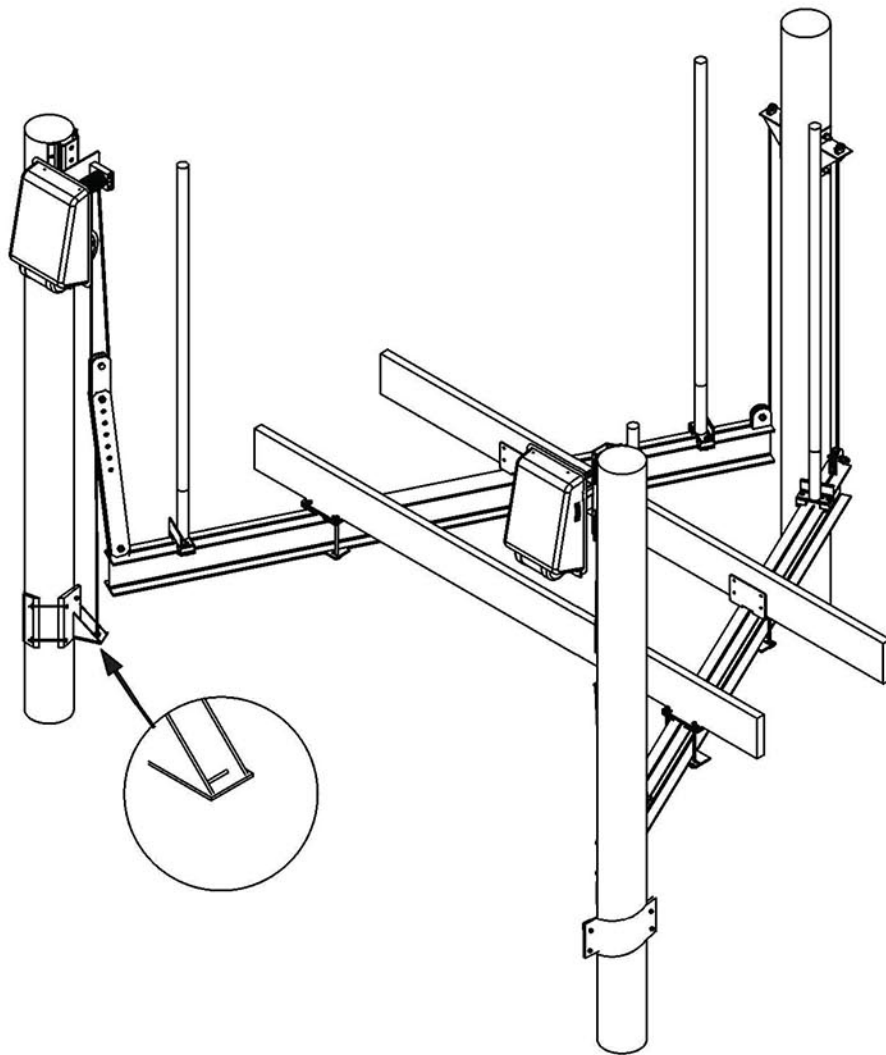

17611 East Street, North Fort Myers, FL 33917

TF: 888-909-5438 PH: 239-337-4141 FAX: 239-337-4482 [www.goldenboatlifts.com](http://www.goldenboatlifts.com)

# GOLDEN BOAT LIFT THREE PILING INSTALLATION

## Mounting Flat Plate Drive Head

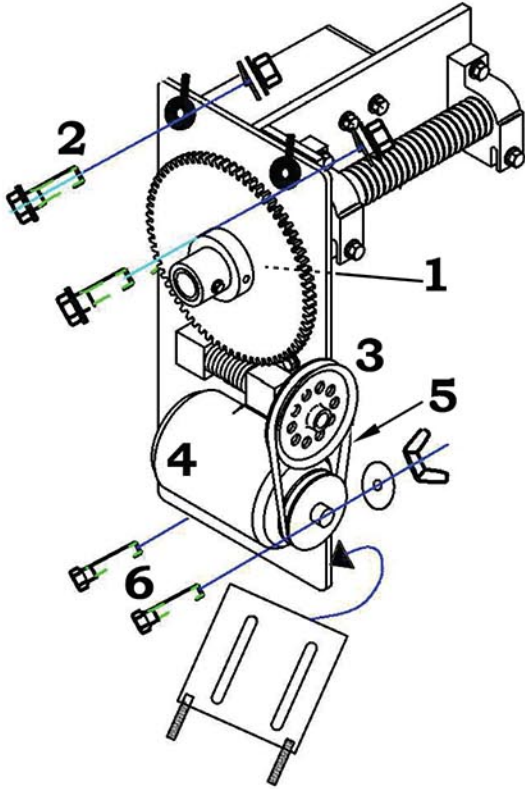

1. Slide the flat plate over the shaft and sleeve, align the holes and secure with hardened bolt and locking nut.
2. Bolt the flat plate to the winder mount angle, use 1/2" x 1 1/4" bolts, nuts, washers and pin washer. (See Illustration)
3. Install motor to the backplate using top holes and short carriage bolts. (provided)
4. Install large V-belt pulley on the worm shaft and align it with the motor pulley.
5. Install V-belt around both pulleys starting with the motor pulley.
6. Install longer carriage bolts in lower motor mounts using wing nuts and sliding pin plate.
7. Verify motor direction. Up is counter clockwise on the large drive gear. See motor wiring instructions to reverse.



17611 East Street, North Fort Myers, FL 33917

TF: 888-909-5438 PH: 239-337-4141 FAX: 239-337-4482 [www.goldenboatlifts.com](http://www.goldenboatlifts.com)

# GOLDEN BOAT LIFT THREE PILING INSTALLATION

## Mounting Sea-Drive Head

- 1 Coat the shaft with Anti-Seize and put the key into the groove. Slide the motor into the gearbox and secure with 4, 1" long bolts.

**!** **CAUTION:** Do not force the motor into the gearbox with bolts. Slide the motor fully into the gearbox by hand.

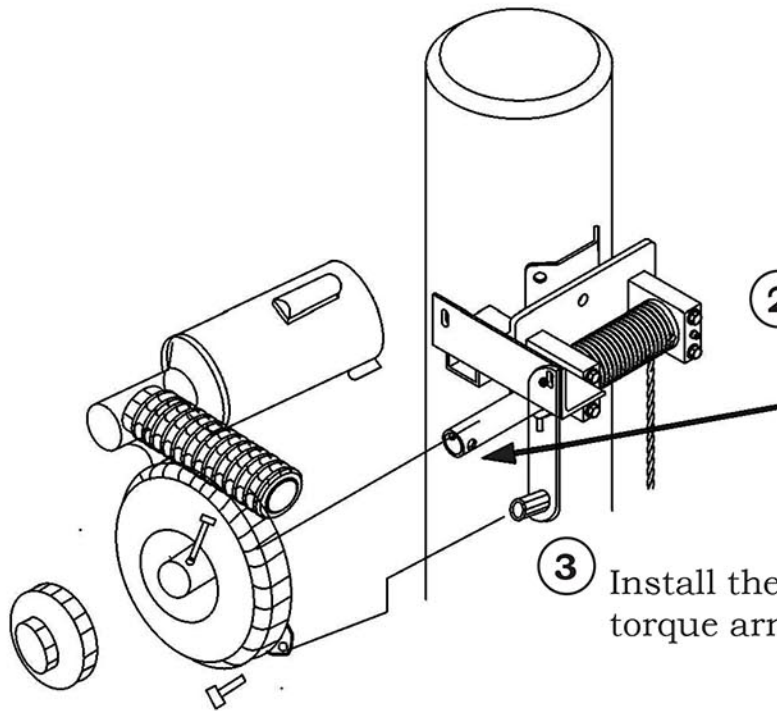
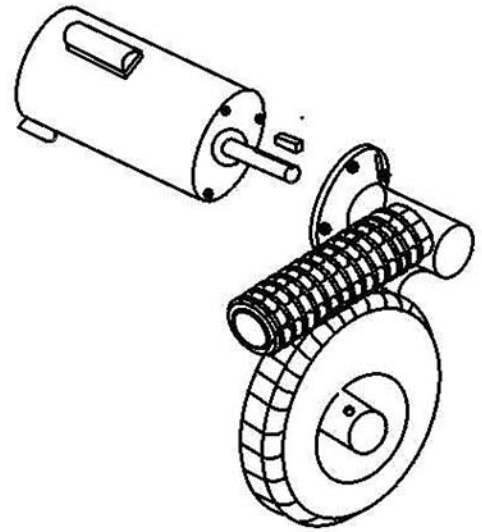

- 2 Slide the gearbox and motor over the shaft and sleeve then secure with drive bolt.

- 3 Install the torque bolt to torque arm and tighten.

- 4 Verify motor direction. Up is counter clockwise on the large drive gear. See motor wiring instructions to reverse.



17611 East Street, North Fort Myers, FL 33917

TF: 888-909-5438 PH: 239-337-4141 FAX: 239-337-4482 [www.goldenboatlifts.com](http://www.goldenboatlifts.com)

# GOLDEN BOAT LIFT

## THREE PILING INSTALLATION

### Installing The Cradles And Cable

- ① Free the cable loop from the winder spool and loop it thru the top pulley by removing the pulley bolt. Drop the loop between plates and replace the pulley and bolt. Repeat for second head.
- ② String the Zee cable from the lower Tie-Off up and over the middle pulley, down and under the cradle pulley, across the cradle beam under the guide poles and bunk supports. Feed the cable thru the upper clamp and secure it with the cable bracket.
- ③ Install bunks using the brackets provided.
- ④ Insert guide poles into receiver tubes.

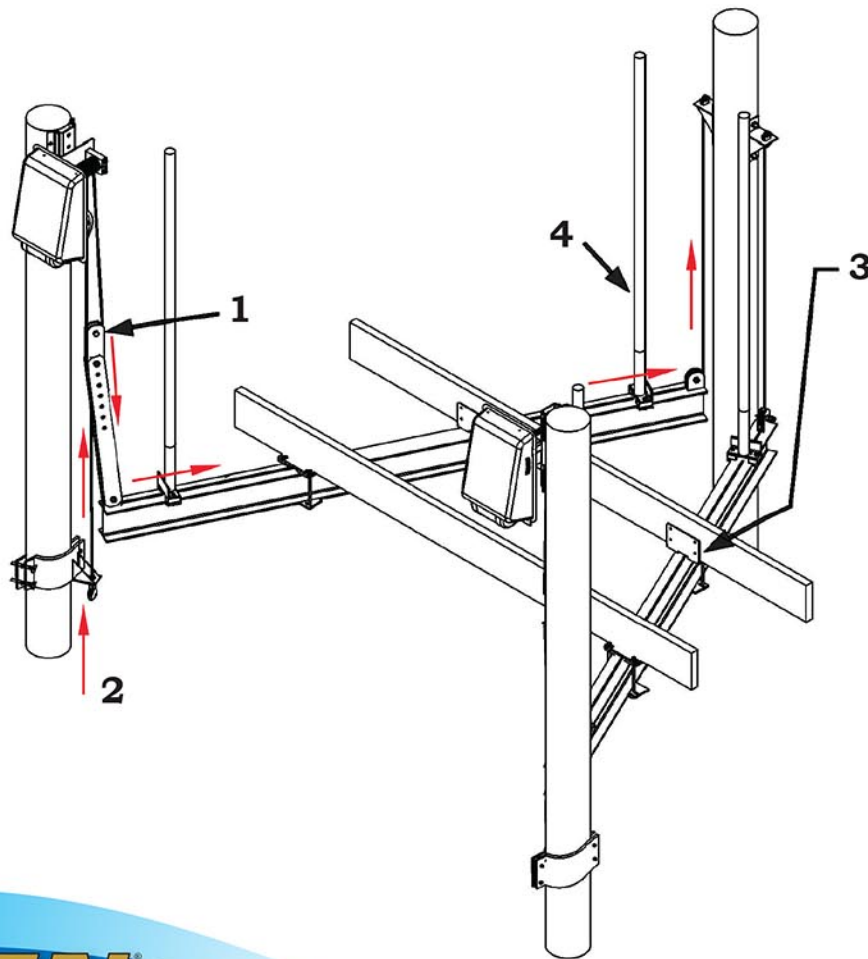

17611 East Street, North Fort Myers, FL 33917

TF: 888-909-5438 PH: 239-337-4141 FAX: 239-337-4482 [www.goldenboatlifts.com](http://www.goldenboatlifts.com)

# GOLDEN BOAT LIFT THREE PILING INSTALLATION

## Bunking The Boat

The weight of your boat must be equally distributed on the beams to ensure your safety, the boat hull and the longevity of the lift.

ALWAYS place the center of gravity of your boat directly in the CENTER of the lift beams.

Adjust the cradle beams to support the hull completely without interfering with any thru hull fittings or features.

Lift the boat a little but not out of the water and inspect the hull support on the bunks in the water. Make any adjustments required. Tighten all of the hardware. Partially lift the boat again and inspect the hull. When the hull is properly supported and verified, only then is it safe to lift the boat.

Adjust the guide poles to fit the hull, they center the boat above the cradle system.

Center the gravity of your boat as a rule of thumb, is about 1/3 distance from the stern and 2/3 distance from the bow. Your boat manufacturer can tell you the exact location. In the illustration below depicting the lift center equal distance side to side and front to back.

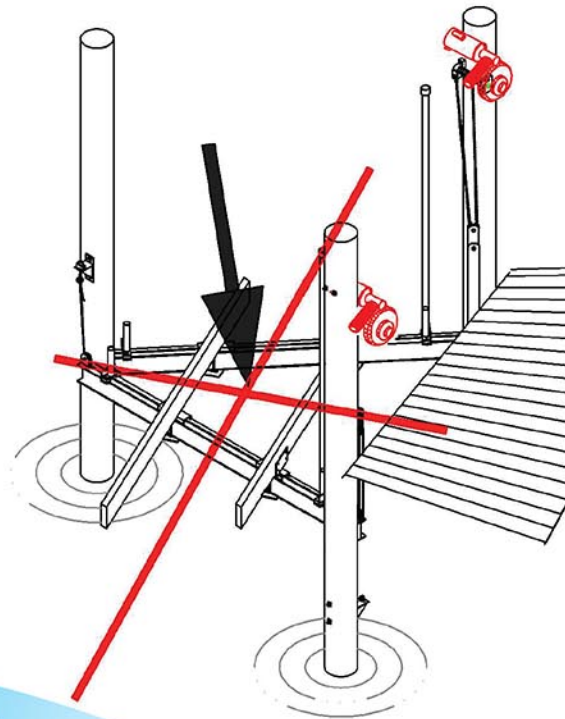

17611 East Street, North Fort Myers, FL 33917

TF: 888-909-5438 PH: 239-337-4141 FAX: 239-337-4482 [www.goldenboatlifts.com](http://www.goldenboatlifts.com)

# GOLDEN BOAT LIFT THREE PILING INSTALLATION

## Final Assembly

At this point the equipment is all in place and you are ready to run the lift. Have the electricity wire the motors and control box. If the lift has an Auto-Stop locate it's position and read the instructions under the cover.

Set Auto-Stop and level the lift.

With the motors wired run the lift up to the approximate final up position. Set the upper limit at this location. Repeat this for the lower limit with the cradles near the floor of the berth. Check both top and lower limit and adjust or fine tune until the lift is stopping correctly.

Adjust the level of the lift using the level switches on the control box. Each motor switch cuts off that motor. Pick the high point and cut off that motor. Run the lift until the low point is raised to level.

Replace all of the covers, check all grease fittings and grease if necessary.

This completes the installation.

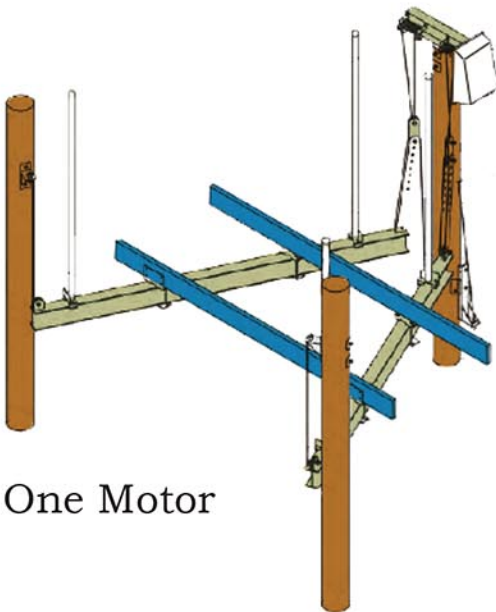

One Motor

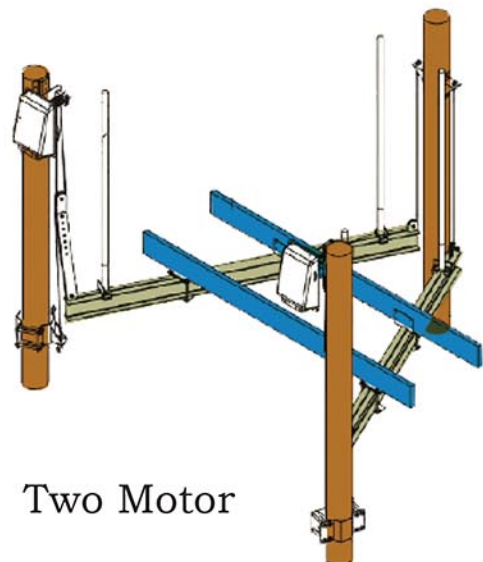

Two Motor



17611 East Street, North Fort Myers, FL 33917

TF: 888-909-5438 PH: 239-337-4141 FAX: 239-337-4482 [www.goldenboatlifts.com](http://www.goldenboatlifts.com)





Dear Customer:

All Elevator Lifts are required to be equipped with one of two electrical safety features in order to prevent damage from electrolysis. You must have either a **4-Pole Disconnect Switch** installed and in the **OFF** position while your boat lift is not in use **OR** a **Removable Power Plug** must be installed and **UNPLUGGED** while lift is not in use. Failure to have either of these devices installed by a licensed electrician may result in corrosion or deterioration of the aluminum track I-beams as well as **VOID** of Warranty. Golden Boat Lifts and their Representatives will not be held liable for damage or failure due to mis installation or oversight of either of the required devices.

Sign: \_\_\_\_\_

Date: \_\_\_\_\_

By signing, I have read, understand, & agree to the requirements listed above

### 4-Pole Disconnect

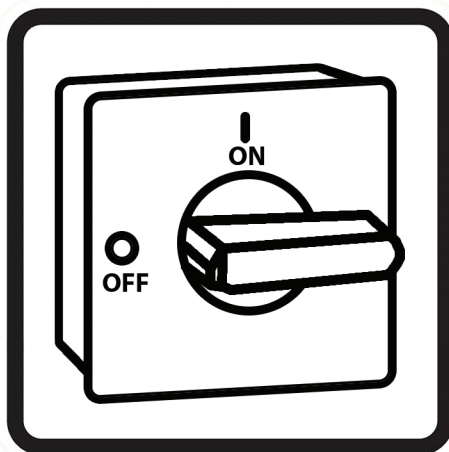

**4-Pole Disconnect installed  
& in off position when Boat  
Lift not in use**

### Power Plug

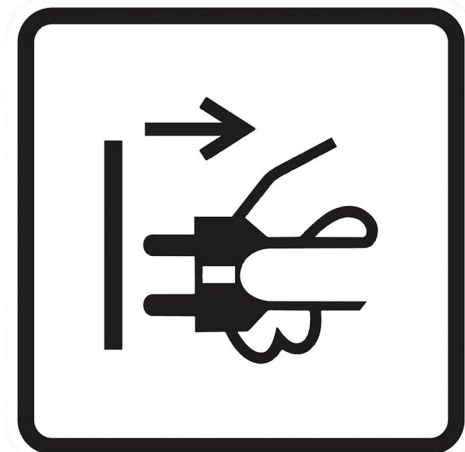

**Disconnect plug when Boat  
Lift not in use**

FAX: 239-337-4482