

GOLDEN ENGINEERED 8 POST, 4 MOTOR BOAT LIFTS

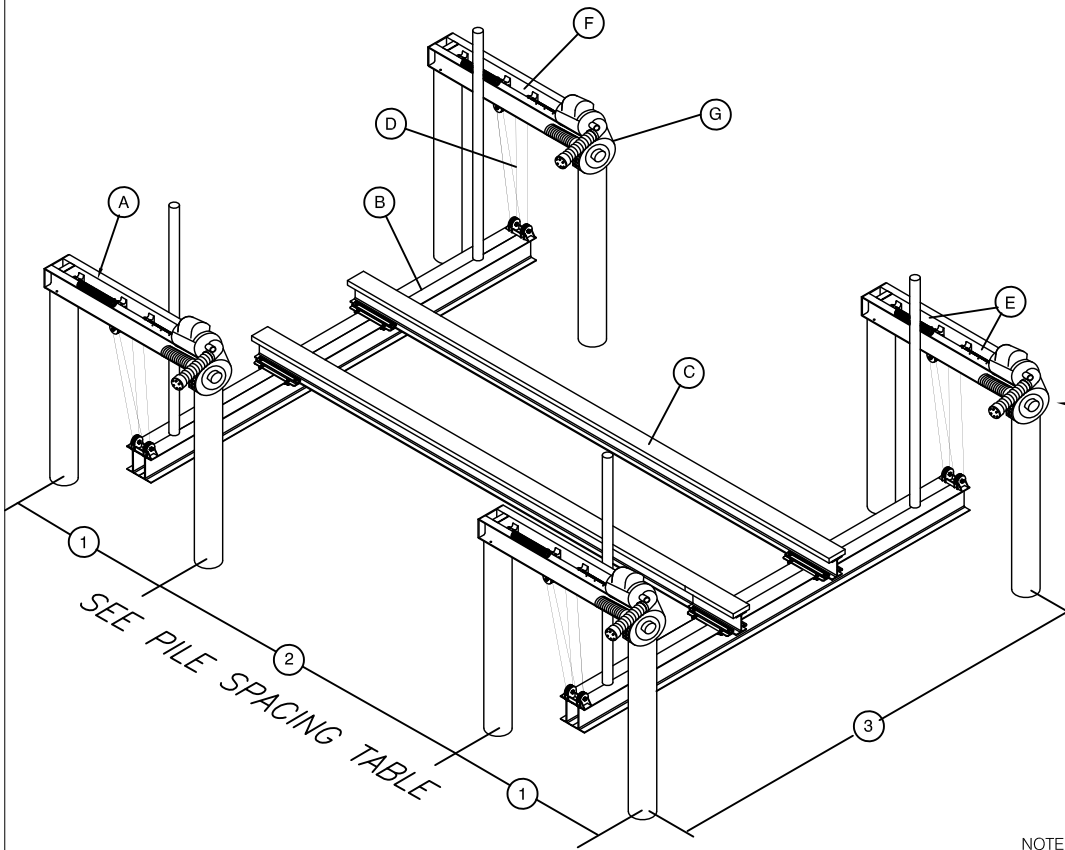

STAINLESS STEEL PILING MOUNT BRACKET - DIMENSIONS VARY WITH APPLICATION

(2) 3/4" CARRIAGE BOLTS USED TO CONNECT THE BRACKETS TO THE LIFT BEAMS

NOTE WOOD PILES (SHOWN BELOW):
 (4) 1/2" DIA SS LAG SCREWS TO BE 4" LONG ON 32/40K LIFTS AND 6" LONG ON 56/60K LIFTS.

CARRIAGE BOLTS TO BE 1/2" DIA. AND LAG SCREWS TO BE 1/2" DIA X 6" LONG ON 80K LIFT

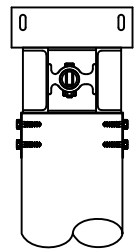

NOTE CONCRETE PILES (NOT SHOWN):
 (2) SS REDHEAD WITH 4" EMBED
 INSTALL AT 8" BELOW TOP OF PILE:

5/8" DIAMETER 32/40K LIFTS
 3/4" DIAMETER 56/60K LIFTS
 7/8" DIAMETER 80K LIFTS

PILE SPACING TABLE

LIFT CAPACITY	1	2	3	RECOMMENDED PILE SIZES
32,000#	72"	MIN. 72" MAX. 144"	192"	10"
40,000#			216"	
56,000#			240"	12"
60,000#				
80,000#				

NOTE: THIS STRUCTURE WILL WITHSTAND LOADS ASSOCIATED AN ULTIMATE WIND SPEED OF 180 MPH, EXPOSURE "D", CALCULATED PER F.B.C. 2020 AND ASCE/SEI 7-16.
 BOATS SHALL NOT BE STORED ON LIFTS DURING HIGH WIND EVENTS
 IN GENERAL PILING PENETRATION TO BE 10' INTO THE SAND BOTTOM OR 5' INTO THE ROCK STRATA. SUBSURFACE CONDITIONS CAN VARY GREATLY, THE CONTRACTOR SHALL VERIFY ALL PILE CAPACITIES. PILINGS TO BE 2.5 C.C.A. TREATED.

LIFT CAPACITY		TOP BEAM		CRADLE I-BEAM		KEEL BEAM		CABLE SIZE		BRGS	WINDER		MOTOR HP	INCHES OF LIFT PER MIN	RECOMMENDED PILING SIZES	
Lb	Kg	Inches	Mm	Inches	Mm	Inches	Mm	Inches	Mm		Inches	Mm			Inches	Mm
32,000	14,528	2 Each 8 H x .19 3 W x .35 Chan 6' O.C.	2 Each 203H x 4.8 76.2W x 7.4 Ch 1.8m O.C.	2 Double 10 H x .25 6 W x .41 192" Long	2 Double 254H x 6.4 152.4Wx10.44 x 4.9M	I-Beam 6 x 10 x .41 x 25' Long w/Carpet Top	I-Beam 152x254 x10.4x7.6M w/Carpet Top	4-4 Part 5/16 St Steel Cables	4-4 Part 7.9 mm St Steel Cables	10 - 2" H.D. 6061-16 Alum Brgs	4-3-1/2"Dia Grooved Alum Winders	4-88 mm Dia Grooved Alum Winders	4 - 1 HP 120V/20A 240V/10A	18.4"	10" Dia Wood or Concrete Pilings	254 mm Dia Wood or Concrete Pilings
40,000	18,160	2 Each 8 H x .25 3-3/4 W x .41 Chan 6' O.C.	2 Each 203H x 6.4 95.3W x 10.4 Ch 1.8m O.C.	2 Double 10 H x .29 6 W x .50 216" Long	2 Double 254H x 7.4 152.4Wx12.74 x 5.5M	I-Beam 6 x 10 x .50 x 25' Long w/Carpet Top	I-Beam 152x254 x12.7x7.6M w/Carpet Top	4-4 Part 3/8 St Steel Cables	4-4 Part 9.5 mm St Steel Cables						8- Solid Nylon Bushings	4 - 5"Dia Grooved Alum Winders
56,000	25,454	2 Each 8 H x .25 5 W x .41 I-BM 6' O.C.	2 Each 203H x 6.4 95.4W x 10.4 Ch 1.8m O.C.	2 Double 12 H x .31 7 W x .62 240" Long	2 Double 304.8H x 9.9 178Wx15.7 x 6M	I-Beam 12 H x .31 7 W x .62 25' Long w/Carpet Top	I-Beam 304.8H x 9.9 178Wx15.7 x 7.62M Long w/Carpet Top	4-4 Part 7/16 St Steel Cables	4-4 Part 11 mm St Steel Cables	4 - 2 HP 120V/24A 240V/12A						
60,000	27,240	2 Each 10 H x .25 6 W x .41 I-BM 6' O.C.	2 Each 254H x 6.4 152.4W x 10.4 Ch 1.8m O.C.	2 Triple 12 H x .31 7 W x .62 240" Long	2 Triple 304.8H x 9.9 178Wx15.7 x 6M	I-Beam 12 H x .31 7 W x .62 25' Long w/Carpet Top	I-Beam 304.8H x 9.9 178Wx15.7 x 7.62M Long w/Carpet Top	4-4 Part 1/2 St Steel Cables	4-4 Part 12.7 mm St Steel Cables							
80,000	36,320	2 Each 10 H x .25 6 W x .41 I-BM 6' O.C.	2 Each 254H x 6.4 152.4W x 10.4 Ch 1.8m O.C.	2 Triple 12 H x .31 7 W x .62 240" Long	2 Triple 304.8H x 9.9 178Wx15.7 x 6M	I-Beam 12 H x .31 7 W x .62 25' Long w/Carpet Top	I-Beam 304.8H x 9.9 178Wx15.7 x 7.62M Long w/Carpet Top	4-4 Part 1/2 St Steel Cables	4-4 Part 12.7 mm St Steel Cables							